



*HOLDER's ingenuity provides simple solutions to your everyday tasks. Innovation and superior design have been HOLDER's legacy for more than a century, and that culminates in the new Tier 3 approved C4.80!*

**SUPERIOR CONTROL AND POWER COMBINATION FOR EXCEPTIONAL MANEUVERABILITY**

HOLDER's patented articulation and oscillation technology provides the operator with unparalleled control and comfort. The patented oscillation/articulation system consists of two steering rams and two stabilizer rams. This articulated chassis creates a perfect twisting motion that applies even pressure to the ground. Complemented by four equal-sized wheels with an integrated stabilizer system, the C4.80 provides the ultimate in traction and maneuverability. Plus an incredible turning radius of only 7.6 feet! Rely on optimum traction, negotiate tight corners easily, work effectively in constrained areas, and handle terrain variations smoothly. Get equipment that will surpass your expectations – *get the HOLDER advantage!*

*HOLDER has long been the industry leader in articulated compact tractors. With its advanced engineering, sleek design, durability and versatility, the C4.80 is your ideal year-round workhorse.*



**HOLDER C4.80**

**SPECIFICATIONS**

<b>WEIGHT (CURB)</b> 4916 lbs. (2230 kg)	<b>PTO</b> 1 3/8" 6 spline dry clutch toggle switch actuation, front and rear. Direction of rotation (in direction of travel), front-clockwise and rear-counterclockwise. PTO RPM: front 540 @ 2260; rear 540 PTO optional
<b>STEERING</b> Articulated design 2-cylinder closed system	<b>CONSTRUCTION</b> Frame construction, 4-wheel drive, articulated steering with hydraulic wheel stabilizer
<b>HYDRAULIC SYSTEM</b> Bosch, gear type, driven by engine. Max operating pressure 190 bar (2800 PSI). Hydraulic Reservoir Capacity: 11 gallons (42 liters)	<b>AIR FILTER</b> Cartridge type with acoustical warning system
<b>FUEL TANK CAPACITY</b> 15.8 gallons (60 liters), fitted with micron fuel filter	<b>ENGINE</b> Deutz, Diesel, 3.6 litre, Model TD2011L04 Turbo, 4 cylinder. Gross HP 83 SAE at 2500 RPM. Direct injection, air/oil cooled, EPA Tier 3 Emissions approved
<b>CONTROL EQUIPMENT</b> 6-function hydraulic bank, single multi function joystick proportional unit. All functions are double acting with a float position, and function lockout	<b>COOLING SYSTEM</b> Integrated air/oil cooled
<b>CAB EQUIPMENT</b>	<b>DIFFERENTIAL LOCK</b> Differential lock; positive 4 wheel lock, electric over hydraulic, mechanically actuating on all 4 wheels by depressing a toggle switch
<ul style="list-style-type: none"> <li>One-man cab, tested and approved under J1040 specifications</li> <li>One door with popout windows (L.H. and R.H.) and ventilation roof hatch for emergency exit</li> <li>Door is removable and replaceable without tools, door positioned with pressurized gas cylinders</li> <li>Interior temperature and sound absorbing lining; test rating 79 dbA</li> <li>Tilt steering</li> <li>Tinted windows</li> <li>Air ride operator's seat is high back, four-way adjustable and self-adjusting for weight</li> <li>2 exterior break-away rear view mirrors (L.H. and R.H.)</li> </ul>	<ul style="list-style-type: none"> <li>4 front headlights, 2 front top working lights, top strobe warning light, front and rear traffic lights, high low beam dash indicator light, brake lights, 4-way flasher, and wired 7-prong trailer plug</li> <li>Lower vision aids (windows) for front attachment hook-up</li> <li>Overhead window for truck loading</li> <li>Windshield wiper and washer front; pantograph design 2 speed intermittent</li> <li>High-performance two-speed heater with pressurized air circulation system; fresh air filter; two speed ventilation fan. Capable of defrosting front, side and rear windows. Heat transfers 22,000 BTU</li> <li>High output integrated air conditioner</li> </ul>
	<b>TRANSMISSION</b> Hydrostatic transmission has automatic load sensing, with electro-mechanical 2 speed. Module varies ground speed to maintain PTO speed
	<b>GROUND SPEED</b> Forward and reverse: Low 0-10 mph (14 kph) Forward and reverse: High 0-21 mph (31.7 kph)
	<b>BRAKES</b> Front drum type, hydraulically actuated. Electro mechanical hand brake with dashboard indicator light
	<b>TURNING RADIUS</b> 7.6 ft. (2.3 meters)
	<b>MAXIMUM ALLOWABLE AXLE LOAD</b> Front: 5511 lb (2500 kg) Rear: 5511 lb (2500 kg)

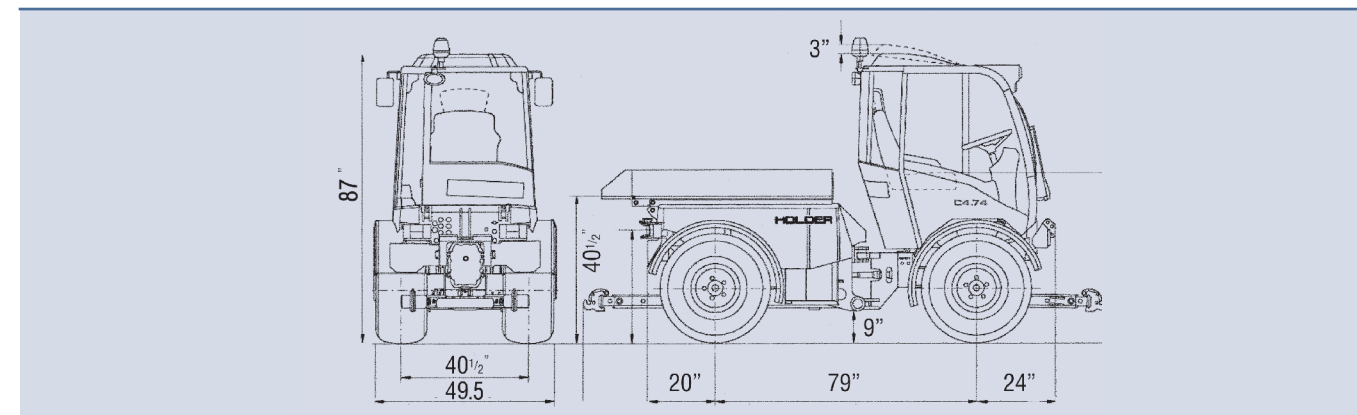

**HOLDER of North America Inc.**  
1351 Barfield Road, Greely, ON Canada K4P 1A1  
1-888-TRACTOR  
Tel: 613 821-4171 Fax: 613 821-1939  
www.holder.on.ca  
info@holder.on.ca

**HOLDER**

This information is intended to be of a general nature only; specifications are subject to change as we continue to improve our products.

**Contact a HOLDER dealer to gain the advantage!**



**C4.80**  
**HOLDER C4.80**



## BEAT THE SEASONS. THE TRUE 4-SEASON MULTI-PURPOSE TRACTOR.



### The ultimate in reach and maneuverability

A boom mower set in front of the operator provides comfort, visibility and safety. The C4.80's low center of gravity eliminates the need for dual wheels allowing the equipment to operate tight to guard rails and maximizing the boom's impressive 13' reach. HOLDER's ergonomic joystick control makes for simple and convenient operation. The boom mower's smart break-away system minimizes the danger of damage from impact.

The boom mower's smart break-away system minimizes the danger of damage from impact.



### We make mowing easy

The operator can engage HOLDER's pendulum system from within the cab so that the 3-point arms can oscillate. This allows the front attachment to carefully hug the contour of the ground, providing a close and even cut without scalping. HOLDER offers a truly professional mowing system — from 60" to 12 feet!

Low center of gravity and smart-engineered weight transfer at the wheels effects superior traction and performance, even with a single set of summer tires! HOLDER's patented stabilizer system allows the tractor to safely negotiate 40° inclines, eliminating the need for special slope-cutting machinery.



### We make the cut

With less vibration and a controlled milling speed, as low as 3 feet per minute, HOLDER's cold planer allows hydraulically controlled angle, depth and sideshift. Add our 150 gallon water tank for superior dust control.

**Integrated High Output A/C** is standard equipment and is strategically located for optimum access to fresh air.

**Reliable & Fuel Efficient** the Deutz 2011 engine provides the power you need to get the job done quickly. Meets Tier 3 Emissions standards.

**Hydrostatic Drive System** provides the convenience and versatility of two speed ranges, plus hand and foot controls. Benefit from the superior traction of constant 4-wheel drive and the C4.80's advanced hydraulic differential locking system.

**Easy Maintenance Access** makes routine servicing quick with both the cab and the over-engine dumping platform conveniently tilting up.

**Redesigned Hydraulic Stabilizer, Articulating & Oscillating Center** HOLDER's patented articulation/oscillation system provides unparalleled maneuverability in virtually any situation. The hydraulic stabilizer assures exceptional control over rough terrain. The C4.80 mounts curbs easily while maintaining even ground pressure on all four wheels.

**Ergonomically Designed Cab** provides excellent 360° vision, overhead visibility for truck loading, and full visibility for attachment hook-up.

**540 rpm PTO** with HOLDER's unique load-sensing system that automatically adjusts ground speed to maintain optimum attachment speed.

**Heavy Duty Front 3-point Arms** adjustable to Category 1 or 2 and feature HOLDER's Hydraulic Front Arm Oscillation for maximum efficiency on uneven contours.

**Hydraulic Accumulator** allows attachments to "float" independently of the tractor, prolonging the life of the tractor, improving handling and reducing operator fatigue.

### Virtually a 360° view

The C4.80's new cab design surrounds the operator with safety glass, providing an unparalleled view of the attachment and surrounding area, including overhead for optimal visibility when truck loading. Simple yet smart, a single joystick controls all functions! Standard features include integrated air-conditioning, intermittent 2-speed wipers, 4-way adjustable air-ride seat, tilt steering, CD Player, pop-out side windows and roof vent.



### Get the HOLDER winter advantage

With the 1.5 cubic yard capacity provided by our sander/dump box combination, operators complete routes faster and without the inefficiencies of refilling the hopper. The C4.80's contoured windshield and optional 5' truck chute make



roadside snow removal easy. Your choice of 50", 60" or 72" blowers and plows make this combination the most efficient and effective snow-fighting package in the world. Even more versatility is gained with our variable plow — it's like having several plows in one!



### Maximize efficiency and minimize downtime

HOLDER's professional sweeping with dust control system defines performance with four nozzles and a 150 gallon water tank. Available in widths of 50", 60" and 72" as well as PTO or hydraulic drive.



1-888-TRACTOR [www.holder.on.ca](http://www.holder.on.ca)